

C-Sailor Pro+

Dental Implantation Systems
USER MANUAL

CE 0197

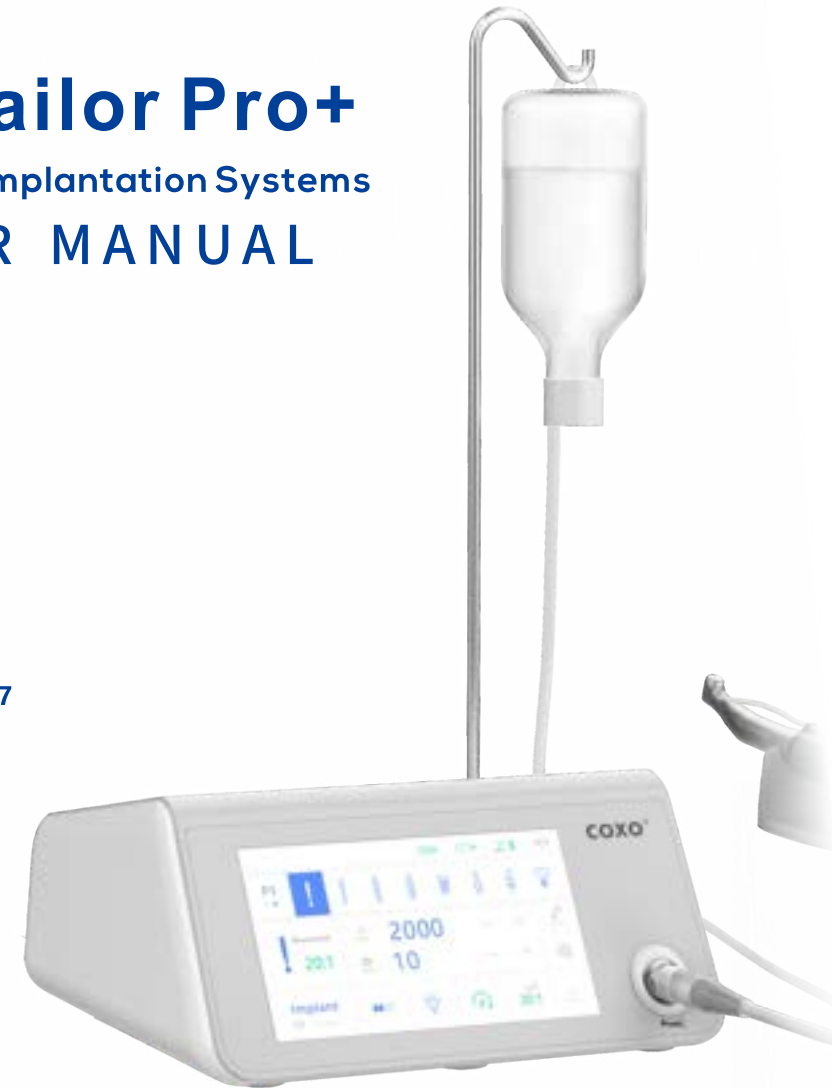

Foreword

The purpose of this manual is to make the operator knowledgeable of the safety precautions, the installation programs, and the instructions for a correct use and maintenance of the device and its accessories. Please read this manual carefully before use.

The manufacturer COXO shall be under no liability, expressed or implied, and shall have no responsibility for any direct, indirect or other damages and personal injury arising out in connection with any practice in the use of the device and its accessories.

COXO is committed to continuously update its products with possible modifications to device components.

CONTENTS

1. Safety	1
2. Intended use	2
3. Contraindication	2
4. Description	3
5. Installation	4
5.1 Motor	4
5.2 Straight or contra-angle handpiece	4
5.3 Irrigation hanger	5
5.4 Irrigation tube	5
5.5 Foot pedal	6
5.6 Power	7
6. Settings	8
6.1 Sound	8
6.2 Pedal pairing	8
6.3 Brightness	9
6.4 Calibration	9
6.5 Factory reset	9
7. Implant mode	10
7.1 Select implant program	10
7.2 Select implant step	10
7.3 Selection and adjustment	12
7.4 Working	15
7.5 Implant program modification	15
7.6 Document	17
8. Surgery mode	20
8.1 Select surgical program	20
8.2 Selection and adjustment	20

8.3 Work	21
9. Calibration	22
10. Factory reset	22
11. Limited mode	23
12. Cleaning, disinfection and sterilization	23
12.1 Cleaning	23
12.2 Disinfection	23
12.3 Cleaning and disinfection	24
12.4 Drying	24
12.5 Packing	24
12.6 Sterilization	25
12.7 Storage	25
13. Maintenance	26
13.1 Replace wireless pedal battery	26
13.2 Replace fuse	26
14. Troubleshooting	28
15. Operating, transport and storage environment	29
15.1 Operating environment	29
15.2 Transport and storage environment	29
16. Technical specifications	29
17. After-sales	30
17.1 Terms and conditions of warranty	30
17.2 Disclaimer	31
18. Recycling and disposal	31
19. Symbols	32
20. EMC	32

1. Safety



Carefully read this manual before proceeding with the installation, use, maintenance, or other operations on the device. Always keep this manual within reach.

- 1) This device is only allowed to be used by professional, trained personnel, such as surgeons. Proper use of the device does not cause side effects; If used improperly, heat will be transferred to tissues, which may lead to tissue damage.
- 2) This device can only be used in the scope of application mentioned in this manual. Failure to follow this instruction will lead to damage or failure of patients, operators and device.
- 3) The device is not provided sterile and must be cleaned, sterilized and sterilized in strict accordance with Chapter 12 before being used for therapeutic purposes.
- 4) Please use original accessories, otherwise the device may be damaged or even cause an injury accident.
- 5) Prevent liquid from seeping through the opening of the device. Failure to do so can cause failure of electronic components.
- 6) Before each treatment, it is necessary to check that the device is in normal operation and its components are effective. If any problem occurs during operation, please stop operation and contact the manufacturer or authorized distributor.
- 7) The device should not be operated in areas where flammable gases (such as anesthetic mixtures) are present.
- 8) Do not start the foot switch when the peristaltic pump cover is open.
- 9) After autoclave sterilization, the Surgical motor should be completely cooled before use.
- 10) The device has electromagnetic interference. Do not use it around patients with cardiac pacemakers or electronic surgery.
- 11) Electromagnetic fields and unstable voltages can interfere with the normal operation of the device.
- 12) Make sure to run tests before each use.
- 13) The electric scalpel will affect the normal operation of this device.

2. Intended use

- 1) This product is intended only for use in the field of dentistry. for surgery to expose and dissect oral tissue structures or endodontic treatments (e.g. periodontal gap, gingival, bone, jaw, extractions and implantations).
- 2) The device is intended for use by suitably qualified and trained medical, technical and specialist staff only.

3. Contraindication

- 1) Systemic diseases (cancer, cardiovascular diseases serious diseases, the blood system, the immune system The disease,.....).
- 2) Ongoing and topical treatment of certain systems (anticoagulant therapy, chemotherapy, radiotherapy,.....).
- 3) Poor quantity and quality of bone.

4. Description

Front

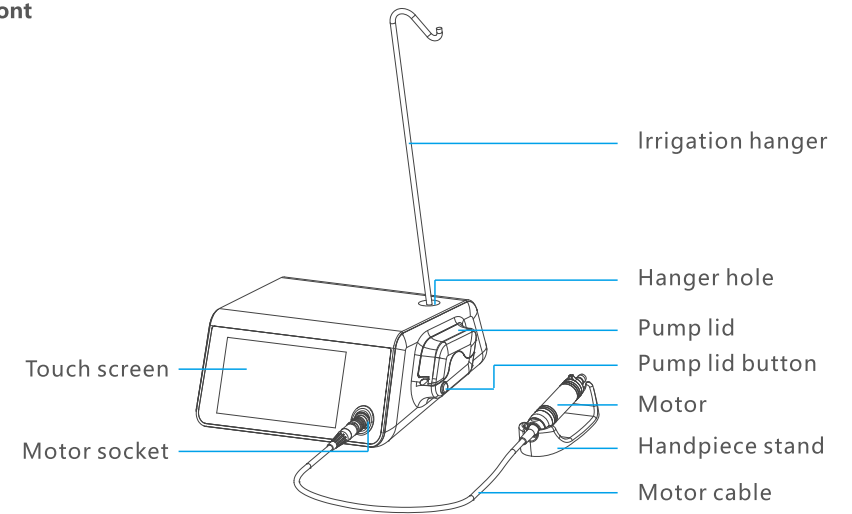

Rear

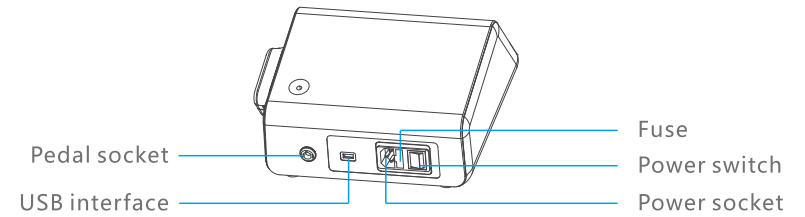

Foot pedal

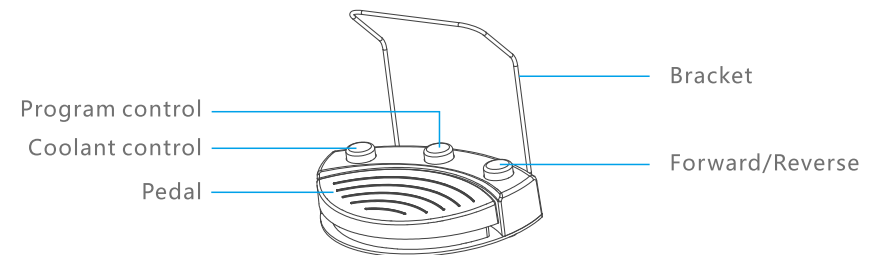

5. Installation

⚠ WARNING

- The device cannot operate in environments where anesthetic or flammable mixtures are present;
- Install the device in a place protected against collisions or against accidental sprays of water or liquids;
- Do not install the device above or near heat sources;
- Foresee adequate air circulation around the device when installing it. Leave adequate space, especially near the fan placed on the back part of the device;
- Do not expose the device to direct sunlight or to sources of UV light.

5.1 Motor

Align the marker points to connect the motor cable with the device.

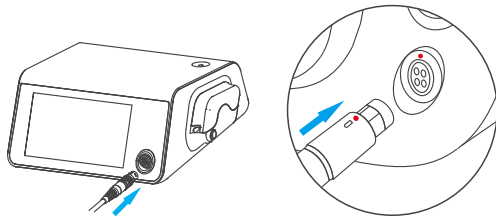

i NOTE

After motor is connected, the status bar of the screen will display the motor status:

- : motor is connected, ■ (twinkle) : motor is undetected,
■ (twinkle) : motor failed, ■ (twinkle) : entered "limited mode" .

5.2 Straight or contra-angle handpiece

- 1) Connect the handpiece to the motor until the pressing sound indicates that the connection is in place.
- 2) Rotate the handpiece to make sure that it is connected firmly.

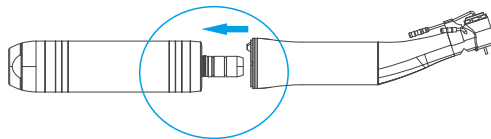

5.3 Irrigation hanger

Insert the irrigation hanger in the hole and hang the irrigation bottle on the hanger.

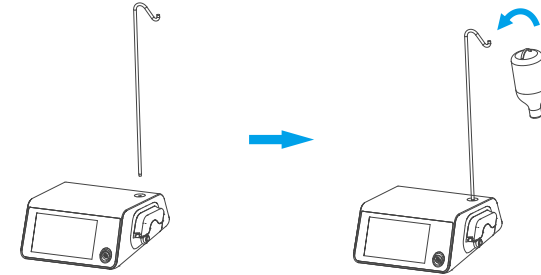

⚠ CAUTION

Use irrigation bottle with a maximal volume of 1.5L only.

5.4 Irrigation tube

i NOTE

The irrigation tubes and bottles mentioned above need to be purchased separately. It is recommended to purchase the ones which registered by the Food and Drug Administration.

- 1) Insert the Irrigation tube needle into the Irrigation bottle.

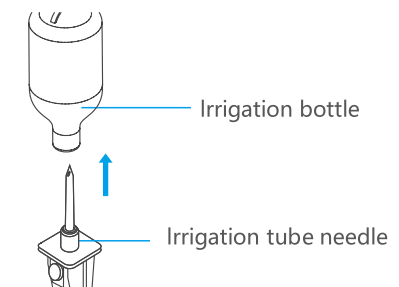

- 2) Press the "OPEN" button and open the pump lid.
- 3) Position the irrigation tube in the pump.
- 4) Close the pump lid completely.

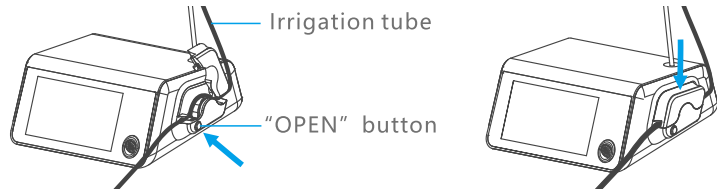

CAUTION

- Turn off the device before opening the pump lid!
- When installing irrigation tubes, make sure they are not squeezed and laid loosely.

5) Connect the irrigation tube with irrigation nozzle on the Handpiece;

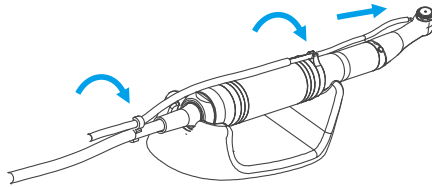

CAUTION

Do not replace the handpiece during operation.

NOTE

Irrigation tubes are disposable and must be replaced after each use.

5.5 Foot pedal

The device can be adapted to wireless pedal and wired pedal.

5.5.1 Connect the bracket to the pedal, and then lock the nut.

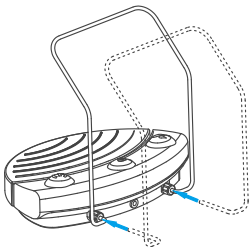

5.5.2 Wireless pedal (when applicable)

The first time you use the wireless pedal, you need to install batteries. The battery installation method is as follows:

Unscrew the cover in the direction of the arrow

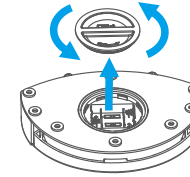

Put in three AA batteries

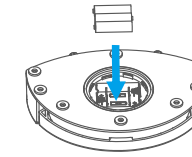

Tighten the cover clockwise

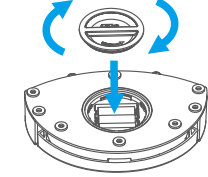

NOTE

- Battery specification is AA * 3. When installing, pay attention to distinguish the positive and negative poles.
- If the wireless pedal is not used for a long time, remove the battery to extend its life.
- Generally, the wireless pedal has been paired before delivery. If you need to re-pair, please refer to "6.2 Pedal pairing" .

5.5.3 Wired pedal (when applicable)

Align the marker points to connect the pedal with the device.

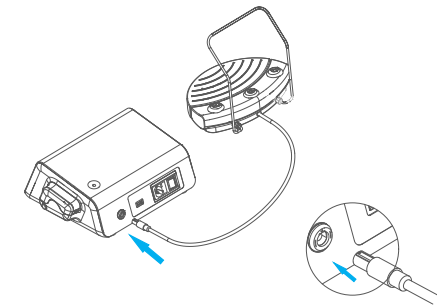

5.6 Power

Connect the Power cord to the device, then connect it to the net power.



Press the power switch to turn on the device.

6. Settings

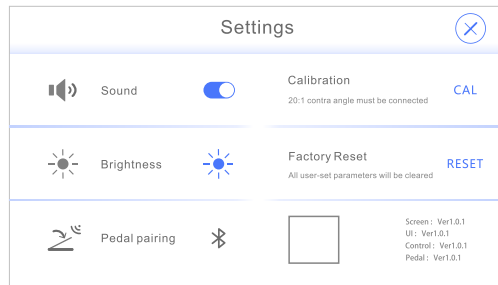
- Press  to enter the settings and press  to exit.





6.1 Sound





- Press  to turn on or off the sound;
-  : sound is on  : sound is off.

6.2 Pedal pairing

- The icon at the top of screen shows the status of foot pedal:

-  (twinkle) No pedals is connected.
-  Wired pedals is connected.
-  Wireless pedal is connected.

NOTE

- The wireless pedal can be used only after it is paired with the control unit. Generally, it has been paired before delivery and can be used directly.
 - If the control unit does not detect the wireless pedal, in addition to checking the battery, you can try to pair again.
 - If the wireless pedal is replaced, it needs to be paired again.
- Press  and follow the prompts.
 - After the pairing is successful, the screen will display  .
 - If the pairing fails, try again.
 - If pedal is paired but not connected to the control unit, the screen will display  .
 - If you need to cancel the pairing press  .

NOTE

Before pairing, keep pressing the pedal.

6.3 Brightness

- Press  to select the screen brightness.

6.4 Calibration

- Calibration function is to adjust the motor torque deviation, in order to ensure its accuracy.
- The motor must be calibrated after each 20:1 contra-angle change, and it is recommended to calibrate before each use.
- See "9. Calibration" for details.

6.5 Factory reset

- See "10. Factory reset"

WARNING

Factory reset will clear all data set by user and cannot be restored.

7. Implant mode

The device contains two modes: implant and surgery, and you can switch by pressing

Surgery / **Implant**
 Implant /  Surgery

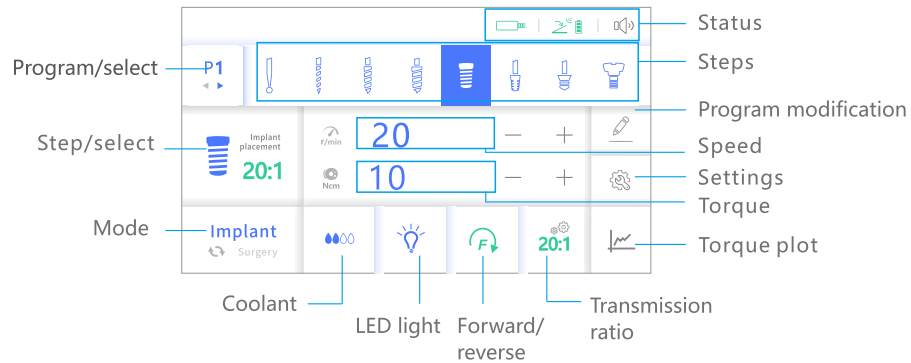

7.1 Select implant program

- The device contains 5 implant programs, from P1 to P5.
- Press **P1** to select the program. The right side of the program number displays all the steps under the program.

NOTE







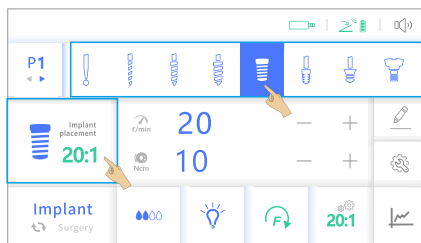





Users can edit the program by combining different steps as needed, refer to "7.5 Implant program modification" for details.

7.2 Select implant step

- Select by pressing the step icon, or pressing the enlarged planting step icon, you can also select by pressing the program control button (P) of the pedal.



- The meaning of the implant step icon is as follows:

Icon	Name	Intended use
	Round drill	For locating and trimming the alveolar crest
	Pilot maker	For penetrating the bone cortex and preliminary determination of axial orientation
	Pilot drill	For marking implant position and axis
	Twist drill1	Minor Diameter Drill
	Twist drill 2	Medium Diameter Drill
	Twist drill 3	Large Diameter Drill
	Profile drill	Shape the upper part of the cortical bone by imitating the shape of the upper end of the implant(osteoporosis is not available)
	Screw press	For pressing on the bone wall of the implant socket
	Implant placement	For implant implantation and removal
	Cover screw	Loading and unloading healing cap
	Rinsing	The motor does not rotate and rinsing separately
	User's drill	User defined freely

7.3 Selection and adjustment

NOTE

Except that Forward/ Reverse of motor is not saved, the device will automatically save other changed parameters.

7.3.1 Coolant

CAUTION

Please ensure sufficient coolant during use.

- The coolant flow can be selected by pressing or pressing  coolant control button on the pedal.



7.3.2 LED light

- Press  to change the brightness of the LED on handpiece.



7.3.3 Forward/reverse

- Press  or Forward/Reverse button of pedal to select direction of motor:



NOTE

For safety reasons, running in counterclockwise direction is not saved.

7.3.4 Transmission ratio

- Press  to select transmission ratio.

CAUTION

The transmission ratio chosen must be consistent with handpiece.

7.3.5 Speed

- Press $+$ / $-$ to adjust the desired value, which is the highest speed when the motor works.

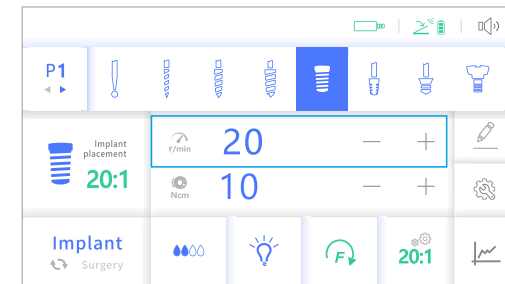





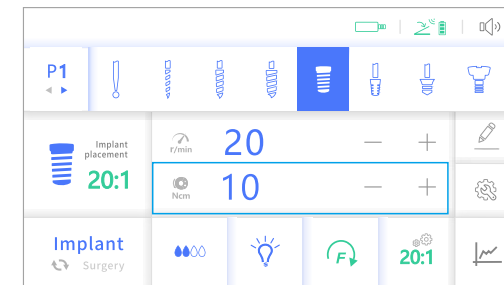







7.3.6 Limit torque

- Press $+$ / $-$ to adjust the desired value, which is the limit torque when the motor works.



The following are the default values for each step:

Icon	Name	Speed (rpm)	Torque(N.cm)	Transmission ratio	Coolant
	Round drill	200-2000 Default:500	5-40 Default:10	20:1	Level 0-4 Default:2
	Pilot maker	200-2000 Default:500	5-40 Default:10	20:1	Level 0-4 Default:2
	Pilot drill	200-2000 Default:500	5-40 Default:10	20:1	Level 0-4 Default:2
	Twist drill 1	200-2000 Default:500	5-40 Default:10	20:1	Level 0-4 Default:2
	Twist drill 2	200-2000 Default:500	5-40 Default:10	20:1	Level 0-4 Default:2
	Twist drill 3	200-2000 Default:500	5-40 Default:10	20:1	Level 0-4 Default:2
	Profile drill	200-2000 Default:500	5-40 Default:10	20:1	Level 0-4 Default:2
	Screw press	15-100 Default:20	5-70 Default:25	20:1	Level 0-4 Default:2
	Implant placement	15-100 Default:20	5-70 Default:20	20:1	-
	Cover screw	15-100 Default:20	5-15 Default:10	20:1	-
	Rinsing	-	-	-	Level 0-4
	User's drill	300-40000 Default:40000	-	1:1	Level 0-4 Default:2
		0	5-70 Default:20	20:1	-

7.4 Working

NOTE

It is recommended to calibrate the motor before each use, refer to "9. Calibration" .

- Press the pedal to start working, and release to stop.
- The speed of motor depends on the pedal pressing force. When pedal is completely pressed, motor rotates at the set speed.
- When the motor is running, the screen displays the resistance in a graphical way:  . Green means the limit torque is within 50%, orange means 50% - 80%, and red means more than 80%. There is an audible signal as soon as the maximum torque is reached.

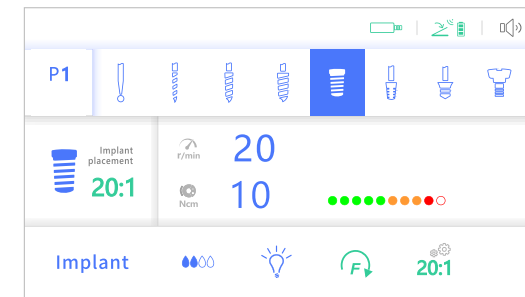

CAUTION

- In case of motor failure, the system will start "limited mode" . In the mode, users can continue to use the device, but some performance is limited.
- "Limited mode" refers to: 11. Limited mode.

7.5 Implant program modification

- Users can combine different steps to form new programs as required. For example, the factory setting program is:

- P1 : for low-density bone.
- P2 : for medium density bone.
- P3 : for high-density bone.
- P4 : implant placement.
- P5 : rinsing.

➤ Press to enter

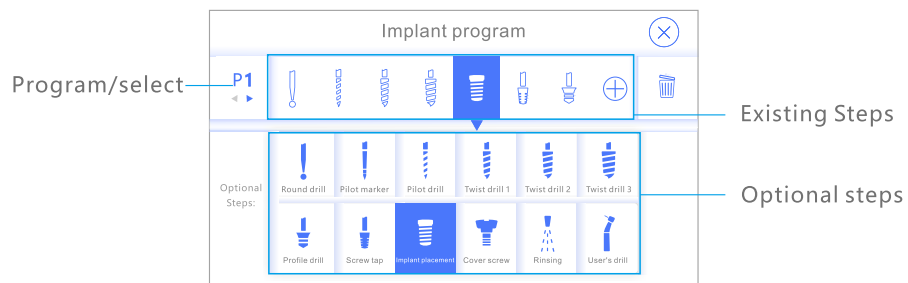

7.5.1 Replace step

- Select the program.
- Press the existing step that needs to be replaced.
- Press the new step.

7.5.2 Add step

- Select the program.
- Press .
- Press the required step.

NOTE

Each program only can contain up to 8 steps. You need to delete the existing steps first, if you want to add.

7.5.3 Delete step

- Select the program.
- Press the existing step you want to delete.
- Press to delete.

NOTE

Each program contains at least one step. If there is only one step, it cannot be deleted.

7.5.4 Exit

- Press to exit.
- "Yes" means to save, "No" means not save, and "Cancel" means returning to the modification screen.

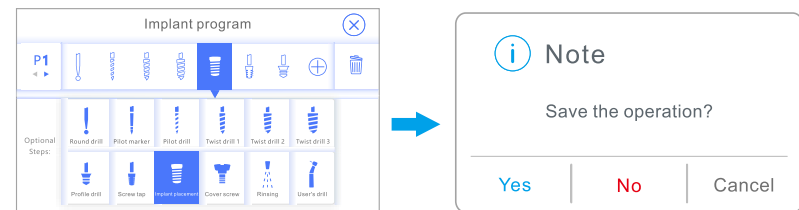

7.6 Document

- A torque plot is shown in the "Implant placement" activity after each motor stop. The plot visualizes the torque profile applied during insertion of the implant. The torque plot can be also stored in the <ID-Date-Implant Position.bmp> file on the USB device.
- Press to view or save the data.

NOTE

- Data storage function is only available during Implant placement activity.
- Save only the last data. If you need to save it, please transfer it to an external USB device.
- The torque plot will be automatically cleared after device is shut down.
- USB storage device uses FAT32 format, and the usable capacity is not less than 2MB.

7.6.1 Torque plot

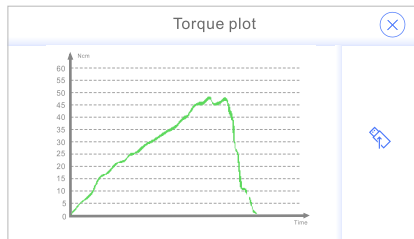

- To transfer to an external USB device, press to continue the operation, and press to exit.

7.6.2 Save

A. Entry information

- Enter the patient ID, name and date.
- Press **Next** to continue.

B. Implant position

- Select the corresponding implant position.

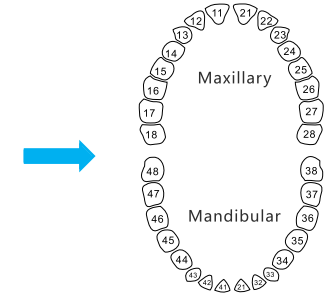

C. Check and save

- Press **Next** to enter "Information" for checking.
- Press **Save**.

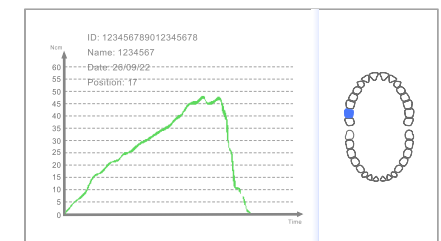

8. Surgery mode

➤ Press **Surgery** / **Implant** to switch to surgery mode.

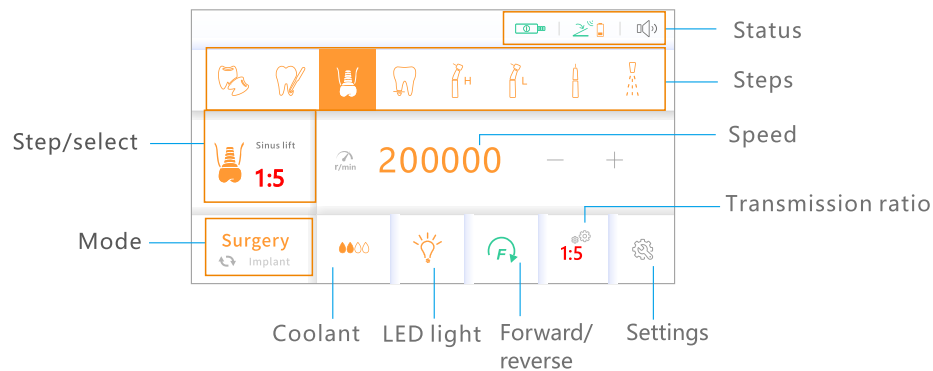

8.1 Select surgical program

➤ Select by pressing the step icon, or pressing the enlarged step icon, you can also select by pressing the program control button (P) of the pedal.

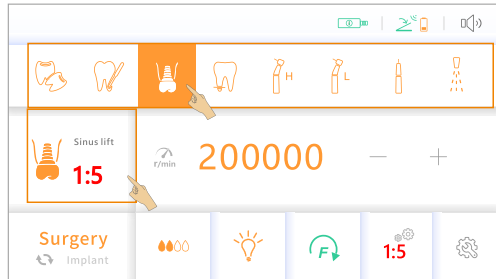

8.2 Selection and adjustment

- Please refer to “7.3 Selection and adjustment” for details.
- Surgical program icon and default values for each step:

Icon	Name	Explanation	Speed	Transmission ratio	coolant	LED light
	Tooth extraction	For tooth extraction	10000-170000 preinstall10000	1:2,1:3,1:4.2,1:5, preinstall1:4.2	Level 0-4	Low light
	Apical resection	Apical resection	10000-170000 Preinstall10000	1:2,1:3,1:4.2, 1:5, preinstall1:4.2	Level 0-4	Low light
	Wisdom teeth	For wisdom teeth	10000-200000 Preinstall200000	1:2,1:3,1:4.2, 1:5, preinstall1:5	Level 0-4	Low light
	Sinus lift	sinus floor elevation	10000-200000 preinstall200000	1:2,1:3,1:4.2, 1:5, preinstall1:5	Level 0-4	Low light
	High speed	High speed (speed increase)	10000-170000 preinstall10000	1:2,1:3,1:4.2, 1:5, preinstall1:4.2	Level 0-4	Low light
	Low speed	Low speed (constant speed or deceleration)	2000-40000 preinstall2000	1:1,4:1,10:1, 16:1,20:1 preinstall1:1	Level 0-4	Low light
	Straight	Straight handpiece	2000-40000 preinstall2000	preinstall1:1	Level 0-4	Low light
	Rinsing	The motor does not rotate and rinsing separately	-	-	Level 0-4	Low light

8.3 Work

- Press the pedal to start working, and release to stop.
- The speed of motor depends on the pedal pressing force. When pedal is completely pressed, motor rotates at the set speed.

CAUTION

- In case of motor failure, the system will start “limited mode” . In the mode, users can continue to use the device, but some performance is limited.
- “Limited mode” refers to: 11.Limited mode.

9. Calibration

- Calibration function is to adjust the motor torque deviation, in order to ensure its accuracy.

NOTE

- The handpiece must be attached for calibration.
- Calibration should be carried out only with contra-angle handpieces with a transmission ratio of 20:1.
- The calibration must be repeated whenever the handpiece is changed.

- Press  to enter “Settings”, then press **CAL** to start calibration.

CAUTION

- The motor will run automatically without pressing the pedal during calibration.
- Hold the motor firmly or put it in a safe holder during the calibration.

10. Factory reset

“Factory reset” can reset the program parameters to the original factory values.

- Press  to enter the setting screen, then press **RESET** and follow the instructions.

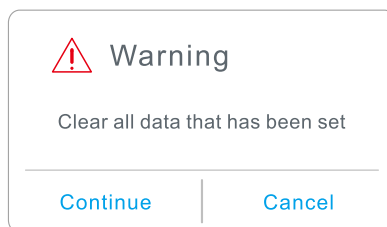

WARNING

Factory reset will clear all data set by user and cannot be restored.

11. Limited mode

- When the motor is partially malfunctioning, the device can start “limited mode”. In this mode, users can continue to use, but some performance is limited.
- Enter “limited mode”, the motor icon changes to  (twinkle).

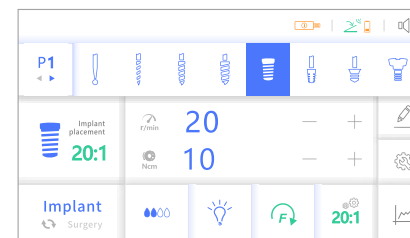

NOTE

- In this mode, some speed and torque are limited, and other functions are the same as those in normal.
- After the power is turned off or the handpiece is plugged in, it will automatically exit the limited mode. If the fault still cannot be solved, please contact the dealer.

12. Cleaning, disinfection and sterilization

NOTE

Please refer to the relevant user manual for the handling steps of the handpiece.

12.1 Cleaning

Wipe the control unit, motor, handpiece, handpiece stand, foot pedal surface and all visible surfaces of the cable with a wet rag.

12.2 Disinfection

NOTE

- After each treatment of a patient, the surfaces near the patient that may have been contaminated by contact or aerosol need to be disinfected.
- All disinfection measures need to be carried out by wipe disinfection.

Use a soft disposable cloth and an approved disinfectant for disinfection by wiping down all visible surfaces of the control unit, motor, handpiece, handpiece stand, foot pedal surfaces and cables.

12.3 Cleaning and disinfection

i NOTE

- Please use the automatic cleaning sterilizer that meets the requirements of ISO15883 standard.
- For details of thermal cleaning, please refer to the operating instructions of the automatic thermal cleaner.

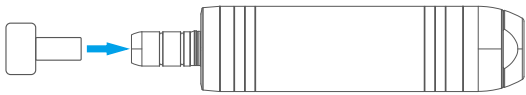

- Screw the protective plug into the motor.

12.4 Drying

i NOTE

The irrigation tubes and its accessories are disposable products, which do not need to be sterilized or dried.

12.5 Packing

i NOTE

- The sterile goods package must be large enough to accommodate the product without stretching the packaging. The quality and use of the packaging of the items to be sterilized must meet the applicable standards and be appropriate for the sterilization process!
- The disinfection process must meet the requirements.

12.6 Sterilization

According to ISO17665-1, the parts of the device to be sterilized are sterilized by steam sterilizer (high temperature autoclave).



The following device parts are allowed to be sterilized:

- Motor and motor cable
- Irrigation hanger

Sterilization requirements:

- 134 °C, no less than 5 minutes.

i NOTE



- Allow all disinfected and sterilized parts to dry fully on room air before using them again
- Please comply with the corresponding Instructions for use when you reprocess the motor and motor cable. COXO recommends washer disinfectors in accordance with EN ISO 15883-1, which are operated using alkaline cleaning agents.
- The products allowed for sterilization have a maximum temperature resistance of 136 °C.

12.7 Storage

The sterilized products must be stored in accordance with all sanitary requirements, dust-proof and dry.

13. Maintenance

13.1 Replace wireless pedal battery

The wireless pedal is powered by battery, and the battery power is displayed in the status bar on the screen.  means the battery is low, please replace in time. 

(twinkle) means the battery is extremely low, please stop working immediately and replace the battery. See "5.5.2 Wireless pedal (when applicable)" for details.

13.2 Replace fuse

NOTE

- If the control unit does not work, check whether the fuse is broken.
- Replace the fuse by pushing open the buckle of the fuse seat with a pointed tool.

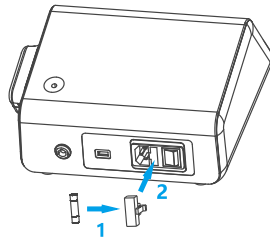

Fuse	
220V	F3.15AL 250V

NOTE

- Because LED only allows DC voltage to be used, the polarity must be connected correctly in order to ensure proper functioning.
- If the LED glows red or does not glow, turn the LED 180 degrees and reinstall it.

CAUTION

Do not touch the bulb after work, and let it cool down.

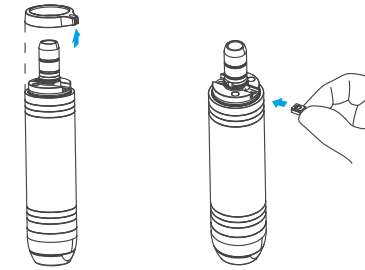

- Rotate to remove the retaining ring.
- Remove the LED.
- Insert a new one into the groove, align it and push it into the base, then attach the retaining ring to the motor.
- Screw up the retaining ring.

NOTE

Do not replace the O-ring when the motor or handpiece working.

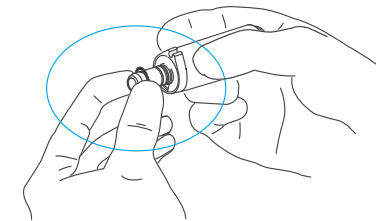

- Remove the O-ring and replace the new one.

14. Troubleshooting

Malfunction	Cause	Remedy
Non-functional device	Blown fuse	Replace a new fuse
Touch screen does not respond	The screen is wet or dirty	Clean the screen
	The film is too thick	Removal of film
	Program crash	Restarting the device
The pedal doesn't work when press it.	The battery has run down	Replace the battery
	Wireless pedal not connected device	Repair
	Bad contact of wired pedal	Reconnect
No coolant or insufficient coolant	Pump lid is not closed	Close completely
	Irrigation tube clamp is closed	Open clamp
	Irrigation tube is kinked	Check and straighten out the bend
	Contra-angle handpiece nozzle is blocked	Clean and dredge
The motor does not run and makes a lot of noise	Motor connection is loose	Reconnect and check that the connection is in place
	Overload	Check whether the straight or contra-angle handpiece is stuck and whether the motor is stuck
	Motor tail cover is not screwed on	Tighten the motor tail cover
	The motor is not properly installed with handpiece	Reinstall and check for firm installation
	Water enters the motor	Drying motor
Motor overheat	The continuous use time of motor is too long or the load is too large	Let the motor cool down before use
The motor has insufficient torque	transmission ratio setting mismatch	Set the ratio consistent with handpiece used
	The handpiece resistance is too large	Replace the straight and contra-angle handpiece and recalibrate the contra-angle handpiece
Speed too fast or too slow	The set ratio does not match the contra-angle handpiece	Set the ratio consistent with handpiece used
No light on the straight or contra-angle handpiece	LED is broken	Replace LED light
	The handpiece is improperly connected	Connect handpiece until it is positioned and locked
	Handpiece without lighting	Use the handpiece with lighting

15. Operating, transport and storage environment



WARNING

Improper working conditions will damage the electrical safety of the device.

15.1 Operating environment

Ambient temperature	+5 °C - +40 °C
Relative humidity	20% RH - 80%RH
Air pressure	860 hPa - 1060 hPa

15.2 Transport and storage environment

Transportation and storage conditions	
Ambient temperature	-10°C - +55°C
Relative humidity	≤93%RH
Air pressure	500 hPa - 1060 hPa

16. Technical specifications

Control unit

Power Supply Voltage	220V ~ 240V
Frequency	50Hz~60Hz
Power Consumption	120VA
Operation mode	Run intermittently, 40s on/ 10 min off
Classified of protection against Electric Shock	Class I
Protection against Electric Shock	Type B applied part
Degree of Protection(IEC 60529)	IPX7(foot pedal)
Classified by security	Non-AP/APG type

Motor

Range of speed	300r/min~40000r/min
Maxima torque (20:1)	80N.cm
Input Voltage	d.c.30V
Motor shaft coupling	Meet the requirements of ISO 3964

Illuminants (LED)

Type of radiation	LED
Typical color temperature	6,000 K
Nominal voltage of the LED	d.c.3.3 V
Voltage range of the LED	2.8 - 3.6 V DC
Maximal LED current	100 mA

17. After-sales

17.1 Terms and conditions of warranty

The manufacturer provides the final customer with a warranty that the product specified in the delivery note functions properly and is free of defects in the material or workmanship. Control unit, foot control and Motor with cable warranty for 24 months from the date of purchase of the product, manufacturers provide free replacement or repair services for reasonable product defect complaints within the timeframes listed below:

Subject to the following conditions:

- Other claims of any nature whatsoever, in particular with respect to compensation, are excluded. In the event of default and gross negligence or intent, this shall only apply in the absence of mandatory legal regulations to the contrary.
- The warranty does not usually cover bulbs, glassware, rubber parts and the colorfastness of plastics.
- Claims from this warranty can only be asserted when the delivery note of the product has been sent to the manufacturer, and the original can be presented by the operator or user.

17.2 Disclaimer

The manufacture will not be responsible for accidents, unit damage, or bodily injury resulting from:





















- Repairs made by personnel not authorized by the manufacture.
- Any changes, modifications, or alterations of its products.
- Maintenance or repairs using parts or components other than those specified by the manufacture and other than in their original condition.
- Operating the unit in ways other than the operating programs described in this manual or resulting from the safety precautions and warnings in this manual not being observed.
- Workplace conditions and environment or installation conditions which do not conform to those stated in this manual such as improper electrical power supply.
- Fires, earthquakes, floods, lightning, natural disasters, or acts of God.

18. Recycling and disposal



Disposal of waste instrument must comply with national regulations and standards. Ensure that all components do not produce pollution during the disposal process.

19. Symbols

	Warning/ Caution		Note
	Follow instruction for use	IPX7	Protected against the effect of immersion
	Thermodisinfectable		Sterilizable in a steam sterilizer at 134°C
	Type B applied part		Keep dry
	This way up		Fragile, handle with care
	Serial number		Special disposal of waste electrical and electronic equipment
	Foot pedal		Catalogue number
	Power on		Power off
	Date of manufacture		Manufacturer
	Alternating current		USB interface
	CE Marking		

20. EMC



NOTE:

- The device meet the EMC requirements of YY0505 standard.
- The user shall install and use according to the EMC information provided in the delivered file.
- Portable and mobile RF communication devices may affect the device performance. Avoid strong electromagnetic interference when used, e.g. near cell phones, microwave ovens, etc.
- The guidelines and manufacturer's statement are attached.



CAUTION:

- The device should not be used in close proximity to or stacked with other device. If they must be used in close proximity or stacked, they should be observed to verify that they work properly in the configuration they are used in.
- Use of accessories and cables other than those sold by the device manufacturers as spare parts for internal components may result in increased the device emissions or reduced immunity.

Number	Name	Length (m)	Shielding
1	Power cord	1.5	NO
2	Foot pedal line	1.8	NO
3	Motor cable	1.6	NO

Guidelines and manufacturer's declaration - electromagnetic emission

The device is intended for use in the electromagnetic environment specified below. The customer or the user of the device should assure that it is used in such an environment.

Emission test	Conformance	Electromagnetic environment - guidelines
RF emissions CISPR 11	Group 1	The device use RF energy only for its internal function. Therefore, its RF emissions are very low and are not likely to cause any interference in nearby in electronic instrument.
RF emissions CISPR 11	Class B	The device is suitable for use in all establishments, including domestic establishments directly connected to the public low-voltage power supply network with specific requirement.
Harmonic emissions IEC 61000-3-2	Class A	
Voltage fluctuations/flicker emissions IEC 6100-3-3	Complies	

Guidance and Manufacturer's Declaration - electromagnetic Immunity			
The device is intended for use in the electromagnetic environment specified below. The customer or the user of the device should assure that it is used in such an environment.			
Immunity test	IEC 60601 test level	Compliance level	Electromagnetic environment - guidelines
Electrostatic discharge(ESD) according to IEC61000-4-2	±8 kV contact ±2 kV ,±4 kV, ±8kV, ±15 kV air	±8 kV contact ±2 kV ,±4 kV, ± 8kV, ±15 kV air	Floors should be wood, concrete or ceramic tile. If floor is covered with synthetic material, the relative humidity must be at least 30.
Electrical fast transient/burst IEC 61000-4-2	±2kV for powersupply lines ±1kV for input/output lines	±2kV for powerlines ±1kV for input/output lines	Mains power quality should be that of atypical commercial or hospital environment.
Surges according to IEC 61000-4-5	±0.5 kV & ±1 kV differential mode ±0.5 kV, ±1 kV &±2 kV common mode	±0.5 kV & ±1 kV differential mode ±0.5 kV, ±1 kV &±2 kV common mode	Mains power quality should be that of atypical commercial or hospital environment.
Voltage dips, short interruptions, and voltage variations on power supply input lines IEC 61000-4-11	<5 % UT for ½ period(> 95% interruption) 40 % UT for 5 period(> 60% interruption) 70% UT for 25 period(> 30% interruption) <5 % UT for 5s(> 95% interruption)	<5 % UT for ½ period(> 95% interruption) 40 % UT for 5 period(> 60% interruption) 70% UT for 25 period(> 30% interruption) <5 % UT for 5s(> 95% interruption)	Mains power quality should be that of atypical commercial or hospital environment. If the user of the device requires continued operation during power mains interruptions, it is recommend that the device be powered from a unit eruptible power supply or a battery.
Power frequency(50/60Hz) magnetic field IEC 61000-4-8	3A/m	3A/m	Power frequency magnetic fields should be at levels characteristic of a typical location in a typical commercial or hospital environment.
Note: U_i is the a.c mains voltage prior to application of the test level.			

Guidance and Manufacturer's Declaration - electromagnetic Immunity			
The device is intended for use in the electromagnetic environment specified below. The customer or the user of the device should assure that it is used in such an environment.			
Immunity test	IEC 60601test levels	Compliance level	Electromagnetic environment - guidance
Conducted RF IEC 61000-4-6	3 Vrms 150 kHz to 80 MHz 6 Vrms in ISM and amateur radio bands 3 V/m 80 MHz to 2.7 GHz	3 Vrms 150 kHz to 80 MHz 6 Vrms in ISM bands 3 V/m 80 MHz to 2.7GHz	Portable and mobile RF communications equipment should be used no closer to any part of the instrument, including cables, than the recommended separation distance calculated from the equation applicable to the frequency of the transmitter.
Radiated RF IEC 61000-4-3	385MHz-5785MHz Test specifications for ENCLOSURE PORT IMMUNITY to RF wireless communication equipment(Refer to table 9of IEC 60601-1-2:2014)	385MHz- 5785MHz Test specifications for ENCLOSURE PORT IMMUNITY to RF wireless communication equipment(Refer to table 9 of IEC60601-1-2:204)	Recommended separation distance $d=1.2 \times$ $d=1.2 \times$ 80 MHz to 800 MHz $d=1.2 \times$ 800 MHz to 2,5 GHz where is the maximum output power rating of the transmitter in watts (W) according to the transmitter manufacturer and d is the recommended separation distance in meters (m). Field strengths from fixed RF transmitters, as determined by an electromagnetic site survey should be less than the compliance level in each frequency range Interference may occur in the vicinity of equipment marked with the following symbol: 

NOTE 1: At 80 MHz and 800 MHz, the higher frequency range applies.

NOTE 2: These guidelines may not apply in all situations. Electromagnetic propagation is affected by absorption and reflection from structures, objects, and people.

Field strengths from fixed transmitters, such as base stations for radio (cellular/cordless) telephones and land mobile radios, amateur radio, AM and FM radio broadcast and TV broadcast cannot be predicted theoretically with accuracy. To assess the electromagnetic environment due to fixed RF transmitters, an electromagnetic site survey should be considered. If the measured field strength in the location in which the device is used exceeds the applicable RF compliance level above, the device should be observed to verify normal operation. If abnormal performance is observed additional measures may be necessary, such as re-orienting or relocating the device.

b Over the frequency range 150 kHz to 80 MHz, field strengths should be less than 3 V/m.

Recommended separation distances between portable and mobile RF communications equipment and the instrument.

The device is intended for use in an electromagnetic environment in which radiated Disturbances are controlled. The customer or the user of the the device can help prevent electromagnetic interference by maintaining a minimum distance between portable and mobile RF communications device (transmitters) and the the device as recommended below, according to the maximum output power of the communications the device.

Rated maximum output power of transmitter (W)	Separation distance according to frequency of transmitter		
	150 kHz to 80 MHz $d=1.2 \times P^{1/2}$	80 MHz to 800 MHz $d=1.2 \times P^{1/2}$	80 MHz to 800 MHz $d=2.3 \times P^{1/2}$
0.01	0.12	0.12	0.23
0.1	0.38	0.38	0.73
1	1.2	1.2	2.3
10	3.8	3.8	7.3
100	12	12	23

For transmitters rated at a maximum output power not listed above, the recommended separation distance d in meters (m) can be estimated using the equation applicable to the frequency of the transmitter, where P is the maximum output power rating of the transmitter in watts (W) according to the transmitter manufacturer.

NOTE1: At 80 MHz and 800 MHz, the separation distance for the higher frequency range applies.
NOTE2: These guidelines may not apply in all situations. Electromagnetic propagation is affected by absorption and reflection from structures, objects and people.



Foshan COXO Medical Instrument Co., Ltd.

No. 17, Guangming Ave., New Light Source Industrial Base,
Nanhai National High-tech Zone, Foshan 528226,
Guangdong P.R. China



Lotus NL B.V.

Koningin Julianaplein 10, 1e Verd, 2595AA, The Hague, Netherlands.
E-mail: info@lotusnl.com
Tel: +31644168999

www.coxotec.com